

eco^{px} SYSTEM

HYBRID POWER SOLUTIONS



Use our energy to save yours



Key features

- » Unique hybrid technology, compatible with solar power, genset, wind power
- » Radical reduction in wireless infrastructure OPEX
- » Increase in site reliability
- » Innovative modular architecture for high availability (redundancy) and reduced maintenance
- » Single controller for management of all aspects of energy generation and storage, as well as load management
- » Rapid return on investment
- » Flexibility to meet evolving network needs

Turn to a telecom power expert for a reliable solution

Environmentally-sound power solutions, combining renewable energy sources with back-up batteries, enable Communications Service Providers to lower costs by reducing reliance on diesel generators.

The eco^{px} solution manages network site power from end-to-end: from energy generation to energy storage, load surveillance and remote management. eco^{px} offers unmatched OPEX, security and reliability benefits.

Applications

Off-grid and intermittent grid Wireless sites

As Communications Service Providers continue to expand their network coverage into rural and remote areas lacking access to reliable electrical grid power, our eco^{px} hybrid solutions are there to provide the reliable power you need, without the need for frequent fuel delivery or service visits.

Broadband and Fixed line

It's not just remote wireless sites which can benefit from eco^{px}. eco^{px} solutions can equally be applied to fixed line and grid-connected applications to help reduce the soaring cost of energy which arises from powering today's 'always on' world.

The Smart Grid

With our off-grid and grid-connected hybrid solutions, optimized cost of ownership, network design/build and sophisticated data acquisition expertise, you're ready for the migration to distributed generation and smart grid energy for your telecom network.

eco^{px} SYSTEM SYSTEM ARCHITECTURE

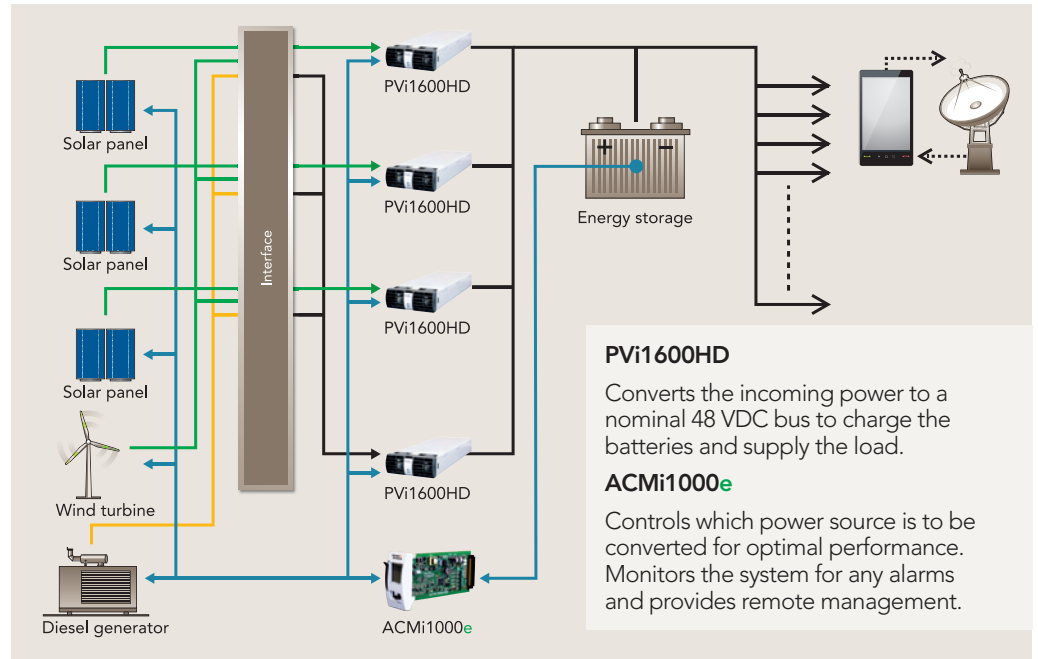

Technical Highlights

AEG PS' eco^{px} hybrid power solution delivers a world of benefits for your network:

- » Use any combination of diesel, solar and wind power sources

A single controller (ACMi1000e) manages the power solution end-to-end, seamlessly selecting the appropriate source for best OPEX

- » Photovoltaic arrays: MPPT-enabled solar converters (PVi1600HD) maximize solar energy production and protect your PV investment

- » Generator: Intelligent management reduces fuel consumption by 50 % or more in generator/battery hybrid configurations by operating the generator for short periods at optimum load to charge the batteries. The results include reduced fuel consumption, less frequent servicing and prolonged generator lifetime - all of which help further reduce OPEX

- » Wind turbine: operating with winds from a 'whisper' to stormforce without shutting down, and with class leading energy yield to reduce OPEX

- » Grid connected (mains): as a primary source or as back-up

- » Batteries: charge rate optimized according to discharge history to maintain the battery in peak condition and prolong its life by up to 25 %. Battery chemistry/technology agnostic

- » Flexibility: the system is designed to be upgradable to meet future expansion.

Integrated Technology

AEG PS' eco^{px} solution has been developed with the benefit of more than six decades of telecom expertise:

- » First fully integrated true hybrid system
- » Flexible, modular solution architecture
- » State-of-the-art, high efficiency, power conversion technology
- » High temperature rated components to avoid the need for special cooling

- » Single, powerful controller to simplify the system

- » Software-implemented algorithms for flexibility and future needs

- » Advanced control command logic and system functionalities

- » Complete data management and data logging

- » Complete remote communication options

Integrated Technology

AEG PS' solutions are specifically designed for use in hybrid telecom systems – in autonomous, remote off-grid systems and grid-connected configurations. Our specialists will optimize the sizing of each power source to provide the best balance of system (BOS) equipment for each site. AEG PS offer a complete solution for all your needs; consulting, system design, products, installation and maintenance.

	eco ^{PX} 4801	eco ^{PX} 1122
POWER OUTPUT		
Maximum configuration	4 x PVi1600HD converters	8 x PVi1600HD converters
Maximum Power (N+1)	4.800 W	11.200 W

PHOTO-VOLTAIC MODE

INPUT SPECIFICATION		
Nominal voltage	255 VDC	
Voltage Range	Full power between 230 to 420 VDC / 170 to 230 VDC with power derating	
Maximum input current	8 A per PV string	
OUTPUT SPECIFICATION		
Nominal voltage	48 VDC	
Voltage Range	42 to 58 VDC	
Full power (N+1)	4.800 W	11.200 W
Maximum output current	90 A	210 A
Efficiency	93 % typical at 50 % load	

DIESEL GENERATOR MODE

INPUT SPECIFICATION		
Nominal voltage	230 VAC	
Voltage Range	Full power between 207 to 253 VAC / 180 to 280 VAC with power de-rating	
Frequency	45 to 66 Hz	
Power factor	0.99 typical from 50 % load	
Maximum input current	34 A	68 A
OUTPUT SPECIFICATION		
Nominal voltage	48 VDC	
Voltage Range	42 to 58 VDC	
Full power (N+1)	6.400 W	12.800 W
Maximum output current	120 A	240 A
Efficiency	91 % typical	
PROTECTION		
PV string surge protection device type II	Yes	
AC input surge protection device type II	Yes	
Number of DC input PV string insulation switches	3	7
AC input protection MCB	Yes	
Input voltage protection	PVi1600HD module – shutdown, in PV mode, with automatic restart when voltage is within operating range	
Soft start	Yes	
Output power & current limiting	Yes	
Input voltage protection	PVi1600HD module – programmable protection with automatic re-start, latched after the second fault	
Hot pluggable converters	Yes	
Thermal protection	Automatic power de-rating and excessive temperature shutdown, with pre-shutdown alarm	
Battery deep discharge protection	Yes	
SYSTEM MANAGEMENT		
Controller	ACMi1000e	
Real time clock	Yes	
Hybrid power sourcemanagement	Yes	
Genset operation optimisation	Yes	
Control & monitoring of converters	Via CAN Bus	
Battery Management	Advanced battery management algorithm, charging modes, temperature compensation, battery tests, current limitation and deep discharge protection	
Load management	Yes	
Alarm detection and management	Yes	

